

TCBGG - - -

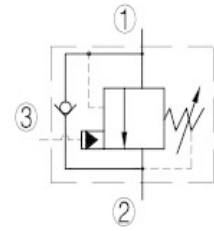
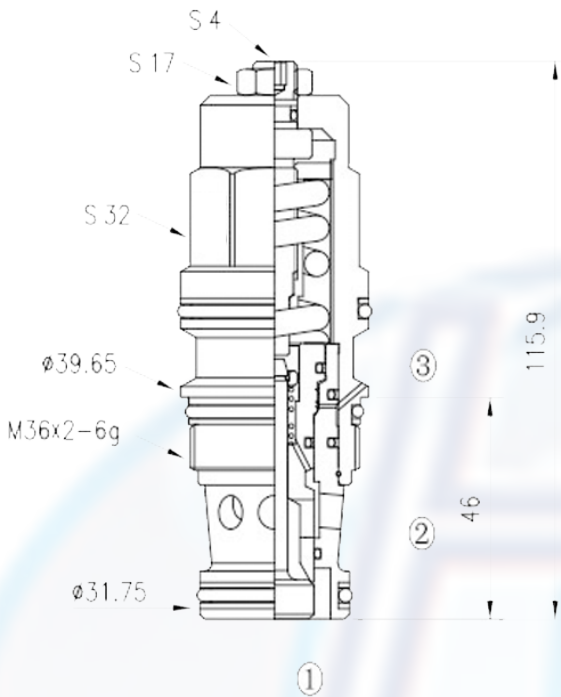

SPECIFICATION:

Max working pressure:	350bar
Flow max:	see performant chart
Internal leakage:	5 drops/min/210bar
Filtration of oil:	25m or better
Temperature:	-30 ~ +110°C
Cavity:	T - 17A
Installatin torque:	200 ~ 215Nm

PERFORMANCE

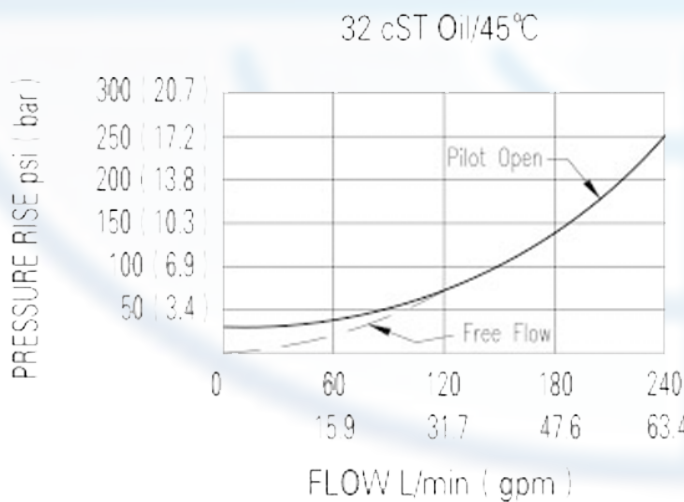

counterbalance valves should be set at leas 1.3 times the maximum load induced pressure.

backpressure at port 2 adds to the effective relife setting at a raito of 1 plus the pilot ratio times the backpressure. reseat exceeds 85% of set pressure when the valve is standard set. Setting lower then the standard set pressure may result in lower reseat percentages.

to order:

TCBGG - - -

Counterbalance valves

PILOT RETIO :

G = 4.5:1

L = standard screw adjustment

SEAL KITS:

N = buna

V = viton

SPRING RANGE:

J = 140 ~ 350bar, preset: 210bar, check: 1.7bar

K = 70 ~ 175bar, preset: 140bar, check: 1.7bar

C = 140 ~ 350bar, preset: 210bar, check: 0.3bar

D = 70 ~ 175bar, preset: 140bar, check: 0.3bar