

TCBGA - - -

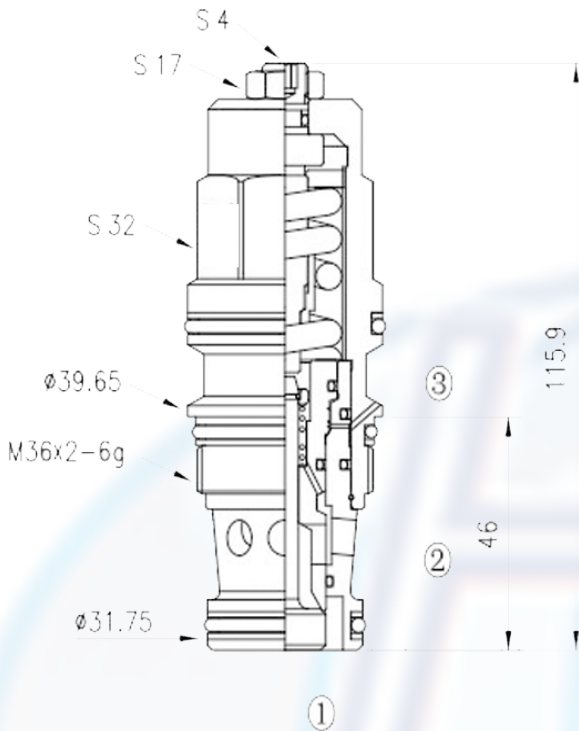
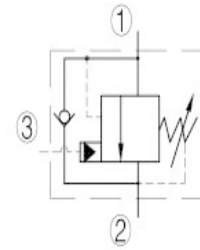

SPECIFICATION:

- Max working pressure: 280bar
- Flow max: see performant chart
- Internal leakage: 5 drops/min/210bar
- Filtration of oil: 25m or better
- Temperature: -30 ~ +110°C
- Cavity: T - 17A
- Installatin torque: 200 ~ 215Nm

PERFORMANCE

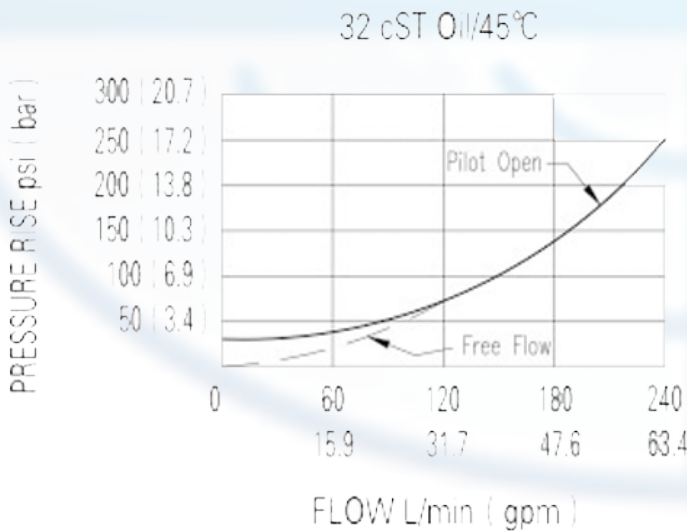

counterbalance valves should be set at leas 1.3 times the maximum load induced pressure.

backpressure at port 2 adds to the effec- tive relife setting at a raito of 1 plus the pilot ratio times the backpressure. reseat exceeds 85% of set pressure when the valve is standard set. Setting lower then the standard set pressure may result in lower reseat percentages.

to order:

TCBGA - - -

SEAL KITS:

Counterbalance valves

N = buna

PILOT RETIO :

A = 3:1

L = standard screw adjustment

SPRING RANGE:

H = 70 ~ 280bar, preset: 210bar, check: 1.7bar

I = 25 ~ 105bar, preset: 140bar, check: 1.7bar

A = 70 ~ 280bar, preset: 210bar, check: 0.3bar

B = 25 ~ 105bar, preset: 140bar, check: 0.3bar