

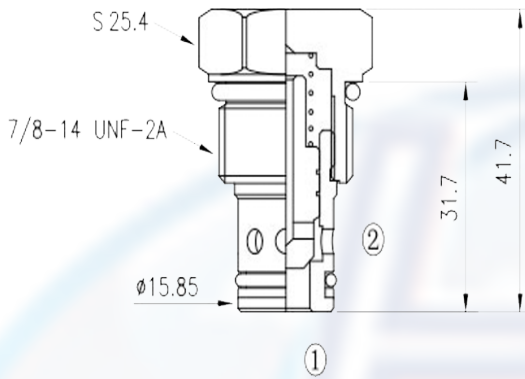

CV - 10 - P

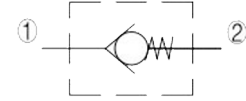

SPECIFICATION:

Max working pressure:	250bar
Flow max:	see performant chart
Internal leakage:	3 drops/min / 250bar
Filtration of oil:	25m or better
Temperature:	-30 ~ +110°C
Cavity:	10 - 2
Installatin torque:	34 ~ 37Nm

PERFORMANCE

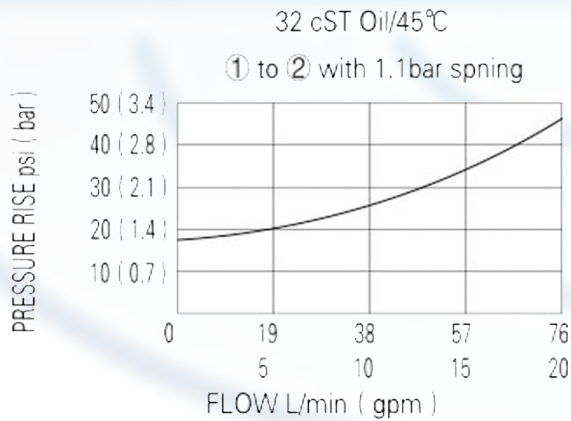

Pressure at 1 overcomes the spring-bias ball and allows free flow 1 to 2.

Flow in the opposite direction, from 2 to 1, is blocked by the ball

to order:

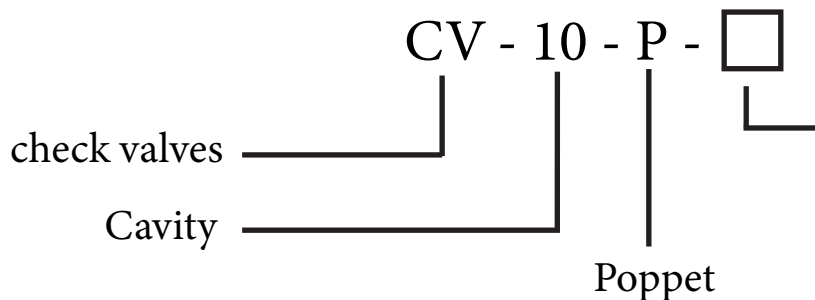

Crack pressure:

0.3 = 0.3 bar

1.1 = 1.1 bar

2.6 = 2.6 bar