

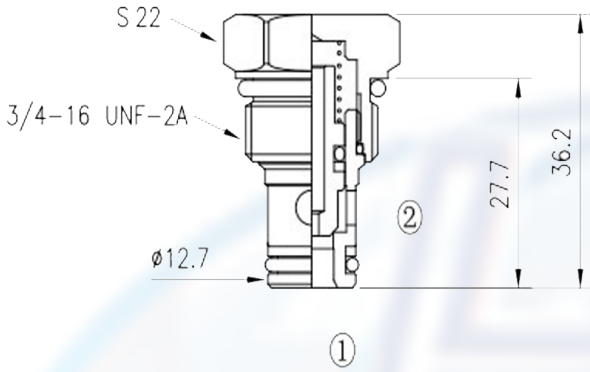

CVR - 08 - P

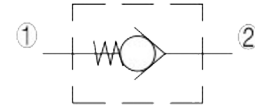

SPECIFICATION:

- Max working pressure: 240bar
- Flow max: see performant chart
- Internal leakage: 3 drops/min / 240bar
- Filtration of oil: 25m or better
- Temperature: -30 ~ +110°C
- Cavity: 08 - 2
- Installatin torque: 25 ~ 28Nm

PERFORMANCE

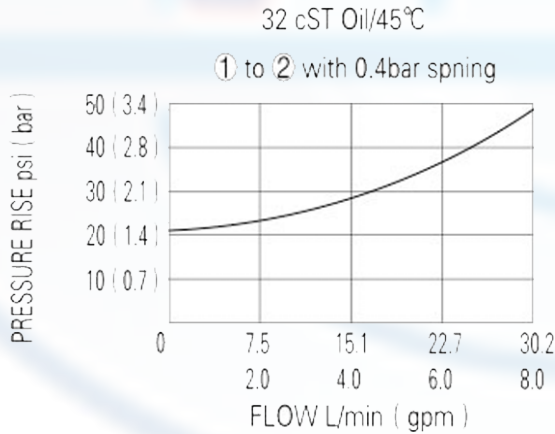

Pressure at 2 overcomes the spring-bias ball and allows free flow 2 to 1.

Flow in the opposite direction, from 1 to 2, is blocked by the ball

to order:

